

TM160B40 Drum Motor (matching Idler KT160B40**)

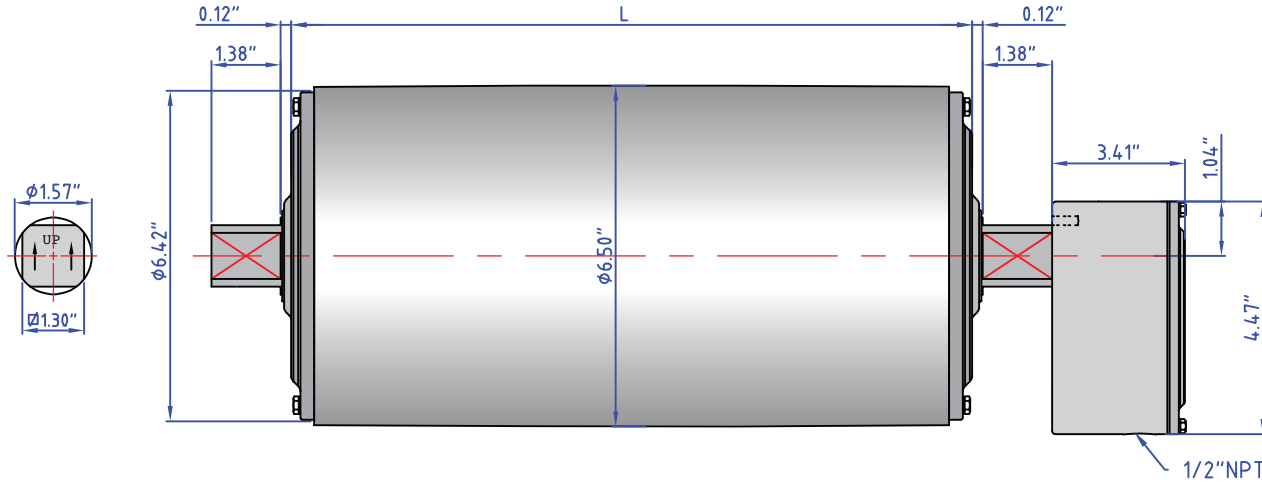

Standard drum motor face widths* (L) in inches:

15.75	16.73	17.72	19.69	21.65	23.62	25.59	27.56	29.53
31.50	33.46	35.43	37.40	39.37	41.34	43.31	45.28	47.24

*Some face widths are not available in all horsepower. For minimum available face widths: [Click Here to View Chart.](#)

**Idler dimensions are identical to the drum motor with no junction box.

Brackets: 160-AB40

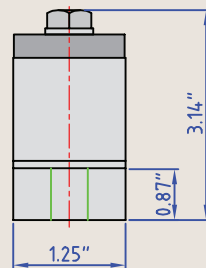
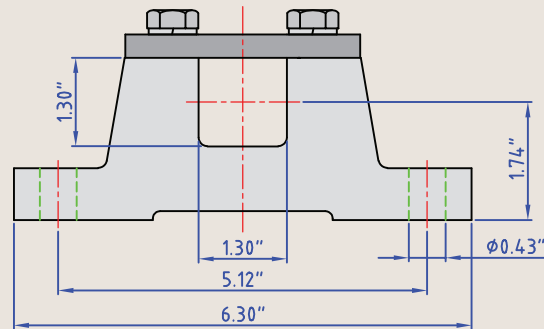

PES Cable Option:

